

HAPAS

Reinforced Earth Company Ltd

Innovation House
Euston Way
Town Centre
Telford
Shropshire TF3 4LT

Tel: 01952 204357

e-mail: info@reinforcedearth.co.uk

website: www.reinforcedearth.co.uk



HAPAS Certificate

12/H182

Product Sheet 1

REINFORCED EARTH SOIL REINFORCEMENT SYSTEMS

GEOSTRAP AND HA GEOSTRAP REINFORCEMENT FOR REINFORCED SOIL RETAINING WALLS AND BRIDGE ABUTMENTS

This HAPAS Certificate Product Sheet⁽¹⁾ is issued by the British Board of Agrément (BBA), supported by National Highways (acting on behalf of the Overseeing Organisations of the Department for Transport; Transport Scotland; the Welsh Government and the Department for Infrastructure, Northern Ireland), the Association of Directors of Environment, Economy, Planning and Transport (ADEPT), the Local Government Technical Advisers Group and industry bodies. HAPAS Certificates are normally each subject to a review every three years.

(1) Hereinafter referred to as 'Certificate'.

This Certificate relates to GeoStrap and HA GeoStrap Reinforcement for reinforced soil retaining walls and bridge abutments, geosynthetic strips used in conjunction with precast concrete facing units and compacted fill material to construct reinforced soil retaining walls and bridge abutments.

CERTIFICATION INCLUDES:

- factors relating to compliance with HAPAS requirements
- factors relating to compliance with Regulations where applicable
- independently verified technical specification
- assessment criteria and technical investigations
- design considerations
- installation guidance
- regular surveillance of production
- formal three-yearly review.

KEY FACTORS ASSESSED

Design — interaction between the soil and GeoStrap and HA GeoStrap Reinforcement has been considered, and coefficients relating to direct sliding and pull-out resistance are proposed (see section 6).

Mechanical properties — the short- and long-term tensile strength and elongation properties of GeoStrap and HA GeoStrap Reinforcement, loss of strength due to installation damage and reduction in strength at the connection to the facing panels have been assessed, and reduction factors established for use in design (see section 7).

Durability — the resistance of GeoStrap and HA GeoStrap Reinforcement to the effects of hydrolysis, chemical and biological degradation and exposure to UV light normally encountered in reinforced soil retaining walls and bridge abutments in the UK has been assessed, and reduction factors established for use in design (see sections 8, 9 and 11).

The BBA has awarded this Certificate to the company named above for the products described herein. These products have been assessed by the BBA as being fit for their intended use provided they are installed, used and maintained as set out in this Certificate.

On behalf of the British Board of Agrément

Date of Third issue: 20 June 2022

Originally certificated on 17 April 2012

Hardy Giesler
Chief Executive Officer



The BBA is a UKAS accredited certification body – Number 113.

*The schedule of the current scope of accreditation for product certification is available in pdf format via the UKAS link on the BBA website at www.bbacerts.co.uk
Readers MUST check the validity and latest issue number of this Agrément Certificate by either referring to the BBA website or contacting the BBA directly.*

Any photographs are for illustrative purposes only, do not constitute advice and should not be relied upon.

British Board of Agrément

Bucknalls Lane
Watford
Herts WD25 9BA

©2022

tel: 01923 665300
clientservices@bbacerts.co.uk
www.bbacerts.co.uk

Requirements

In the opinion of the BBA, GeoStrap and HA GeoStrap Reinforcement for reinforced soil retaining walls and bridge abutments, when used in accordance with the provisions of this Certificate, will meet the requirements of National Highways and local Highway Authorities for the design and construction of reinforced soil retaining walls and bridge abutments.

Regulations

Construction (Design and Management) Regulations 2015 **Construction (Design and Management) Regulations (Northern Ireland) 2016**

Information in this Certificate may assist the client, designer (including Principal Designer) and contractor (including Principal Contractor) to address their obligations under these Regulations.

See sections: (1) *Description* and the *Installation* part of this Certificate.

Additional Information

CE marking

The Certificate holder has taken responsibility for CE marking the products in accordance with harmonised Standard BS EN 13251 : 2016.

Technical Specification

1 Description

GeoStrap and HA GeoStrap Reinforcement

1.1 GeoStrap⁽¹⁾ and HA GeoStrap⁽¹⁾ Reinforcement for reinforced soil retaining walls and bridge abutments is used in conjunction with precast concrete facing units and compacted fill material to construct reinforced soil retaining walls and bridge abutments. The reinforcement strips are connected to the precast concrete facing units either via galvanized mild steel loops and toggles or via proprietary GeoMega⁽¹⁾ or GeoCore or FlexiCore connectors made from high-density polyethylene (HDPE).

(1) GeoStrap, HA GeoStrap and GeoMega are registered trademarks.

1.2 GeoStrap and HA GeoStrap Reinforcement are geosynthetic strips comprising a number of discrete channels of individually tensioned, closely packed, high-tenacity polyester tendons, encased in a low-density polyethylene (LDPE) sheath (see Figures 1 and 2).

Figure 1 Geostrap

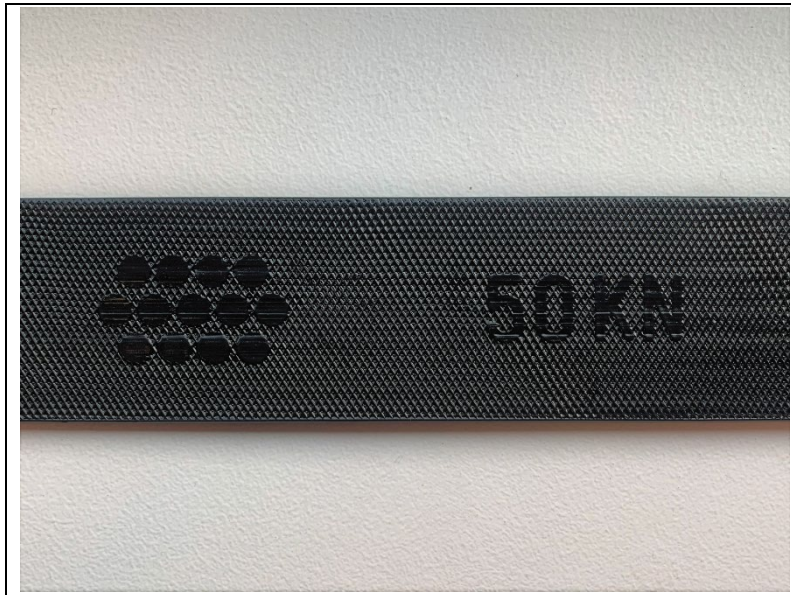

Figure 2 HA Geostrap



1.3 The types and grades of GeoStrap and HA GeoStrap Reinforcement for reinforced soil retaining walls and bridge abutments assessed by the BBA and covered by this Certificate are shown in Tables 1 and 2.

Table 1 Dimensions and short-term tensile strength (GeoStrap)

Type	Strength grade (kN)	Coil length (m)	Nominal Weight of coil (kg)	Mean width (mm)	Mean thickness (mm)	Weight of LDPE Coating (g·m ⁻¹)	Characteristic short-term tensile strength ⁽¹⁾ (T_{Char})(kN)
5	37.5	100	11.3	49.5 ± 0.5	2.5 ± 0.5	≥60	37.5
5	50	100	14.0	49.5 ± 0.5	4.0 ± 0.5	≥68	50
5	65	100	18.2	49.5 ± 0.5	4.5 ± 0.5	≥87	65
9	30	100	14.6	90 ± 1.0	1.5 ± 0.5	≥102	30
9	50	100	19.3	90 ± 1.0	2.5 ± 0.5	≥121	50
9	75	100	26.2	90 ± 1.0	3.5 ± 0.5	≥145	75
9	100	100	30.4	90 ± 1.0	4.0 ± 0.5	≥160	100

(1) Short-term tensile strength of virgin material in accordance with BS EN ISO 10319 : 2015.

Table 2 Dimensions and short-term tensile strength (HA GeoStrap)

Type	Strength grade (kN)	Coil length (m)	Nominal Weight of coil (kg)	Mean width (mm)	Mean thickness (mm)	Inner Width (mm)	Outer Width (mm)	Peak to peak distance (mm)	Weight of LDPE Coating (g.m ⁻¹)	Characteristic short-term tensile strength ⁽¹⁾ (T _{Char})(kN)
5	37.5	100	13.5	49.5 ± 0.5	3.2 +-0.5	40 +-1.5	49.5 +-0.5	28 +-1	≥82	37.5
5	50	100	16.5	49.5 ± 0.5	4.5 +-0.5	40 +-1.5	49.5 +-0.5	28 +-1	≥93	50

(1) Short-term tensile strength of virgin material in accordance with BS EN ISO 10319 : 2015.

1.4 The product type and CE mark are embossed on one face of the products during the manufacturing process, and the product grade and company logo are embossed on the other face (see Figure 3).

Figure 3 GeoStrap Reinforcement — face markings

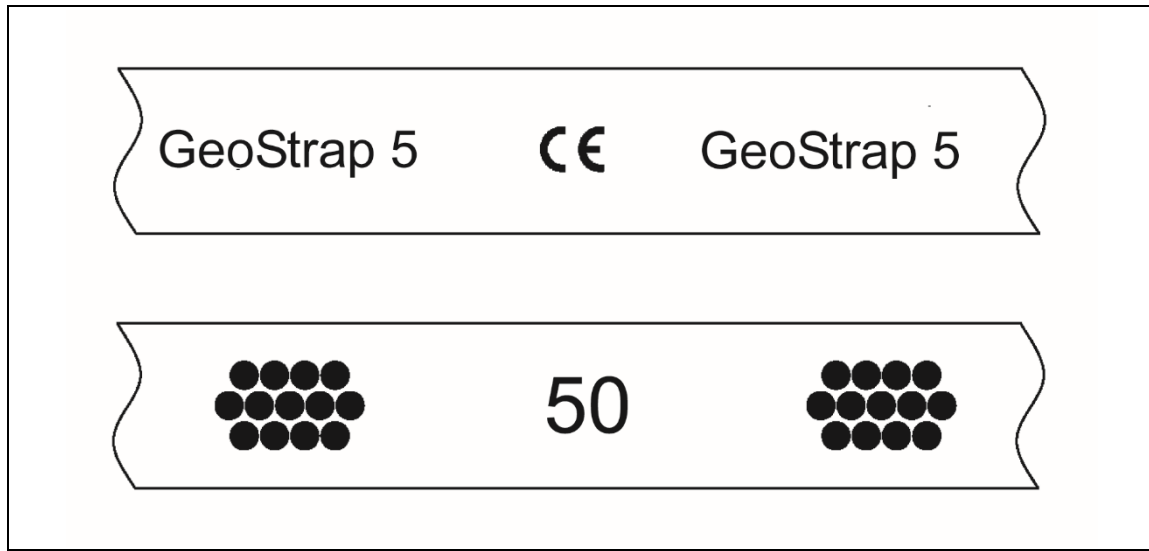

Specification for precast concrete facing units

1.5 The BBA has assessed GeoStrap Reinforcement for use with precast concrete facing units designed and manufactured in accordance with BS 8006-1 : 2010, BS EN 14475 : 2006, BS EN 1990 : 2002 and its UK National Annex, and BS EN 1992-2 : 2005 and its UK National Annex, and the requirements of sections 6.7 to 6.13 of this Certificate. Other facing systems are available but are outside the scope of this Certificate.

1.6 The following four alternative means of attaching GeoStrap Reinforcement to the precast concrete facing units have been assessed by the BBA:

- loops — galvanized steel attachment loops cast into the concrete during manufacture of the precast concrete facing units, with galvanized steel toggle bars spanning between them (see Figure 4). This system can be used with all grades of GeoStrap Reinforcement. The strip is wrapped around the toggle bars during installation. All metallic components must be designed to BS 8006-1 : 2010. The toggle bars must have a minimum diameter of 25 mm (see sections 6.7 and 7.9 of this Certificate)
- GeoMega connectors — one-piece, HDPE sleeve (see Figure 5) cast into the concrete during manufacture of the units. This system can only be used with Type 5 (50 mm wide) GeoStrap Reinforcement. The strip is pulled through the sleeve during installation with the aid of a draw chord. As with steel attachment loops, the pull-out strength is dependent upon the concrete strength, unit dimensions and reinforcement details⁽¹⁾. This system gives a minimum bend radius of 22.5 mm (equivalent to a 45 mm diameter toggle bar).
- GeoCore (Figure 6) connectors are casted into the concrete during the manufacture of the precast concrete facing units
- FlexiCore (Figure 7) connectors are casted into the concrete during the manufacture of the precast concrete facing units. FlexiCore is a silicon mold removed after casting, leaving the space to thread the reinforcement.

(1) For more information, the advice of the Certificate holder should be sought.

Figure 4 Typical connection detail (galvanized steel loops)

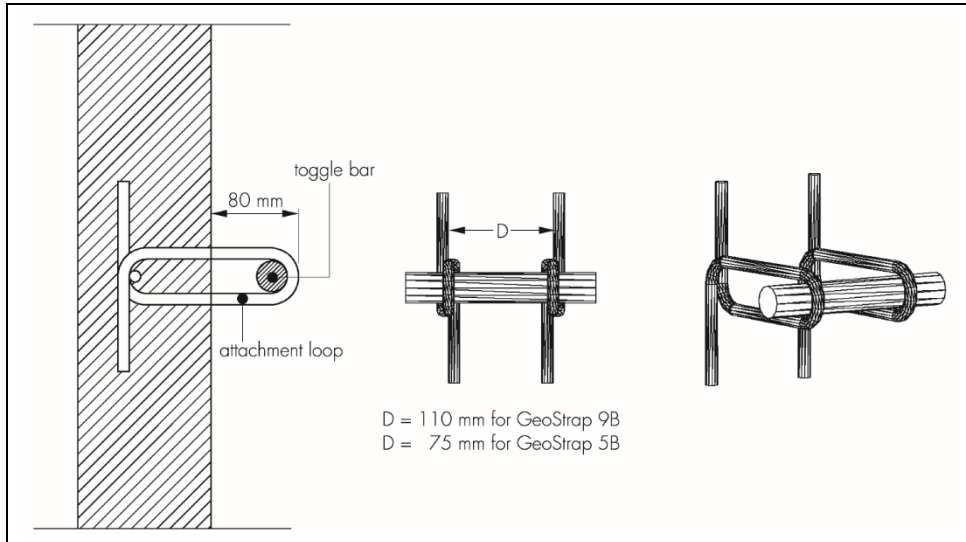

Figure 5 GeoMega connector

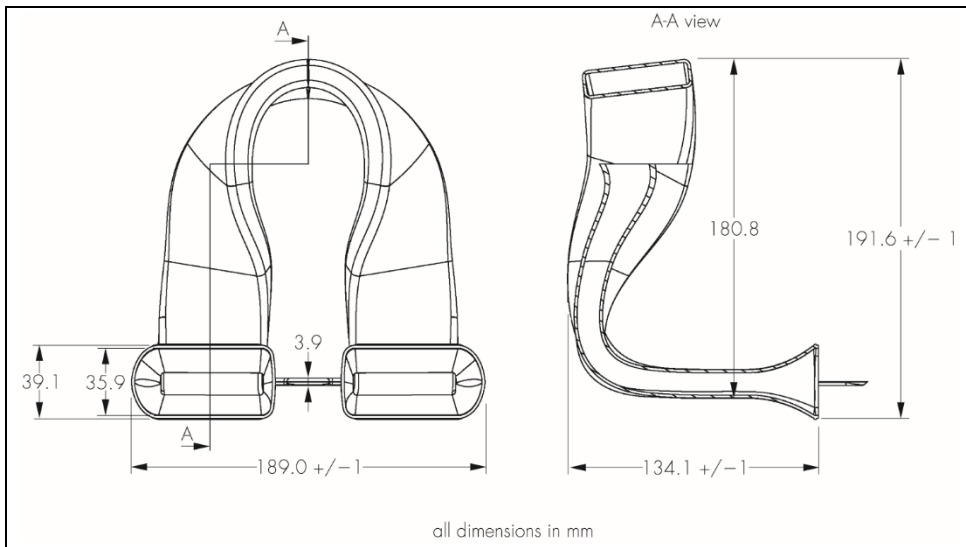

Figure 6 GeoCore connector

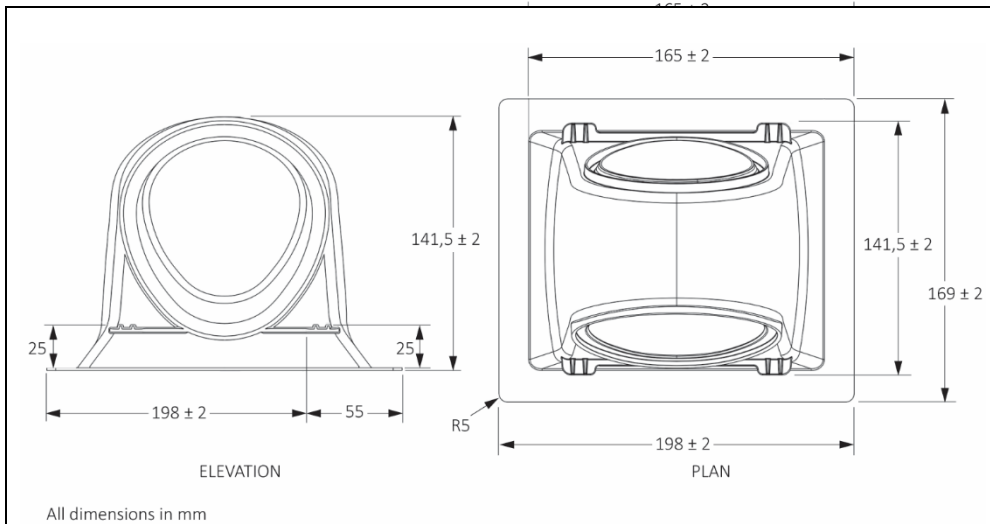
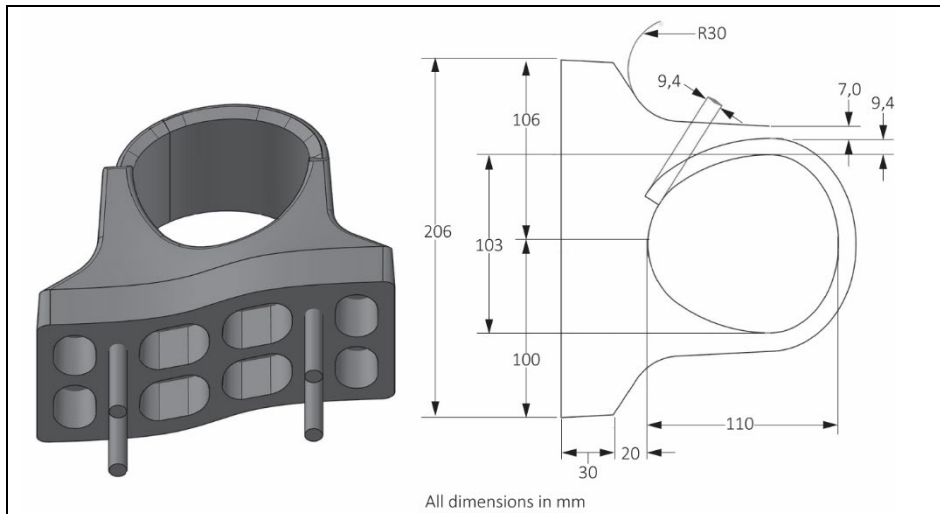

Figure 7 FlexiCore connector



Specification for fill materials

1.8 Fill materials must comply with the requirements set out in BS 8006-1 : 2010 and the *Manual of Contract Documents for Highway Works (MCHW)*, Volume 1 *Specification for Highway Works (SHW)*.

Ancillary items used during installation

1.9 The following ancillary items are used during installation, but are outside of the scope of this Certificate:

- clamps and wedges — to temporarily hold the units in position during installation
- timber pegs or steel pins — for temporary fixing of GeoStrap and HA GeoStrap Reinforcement.

2 Manufacture

2.1 GeoStrap and HA GeoStrap Reinforcement for reinforced soil retaining walls and bridge abutments are manufactured from high-tenacity polyester yarns individually and homogeneously tensioned and packed, then drawn through a die for extrusion-coating in an LLDPE sheath. The strip is then fed between rollers to emboss markings, ensure dimensional accuracy, and are cooled.

2.2 As part of the assessment and ongoing surveillance of product quality, the BBA has:

- agreed with the manufacturer the quality control procedures and product testing to be undertaken.
- assessed and agreed the quality control operated over batches of incoming materials.
- monitored the production process and verified that it is in accordance with the documented process.
- evaluated the process for management of nonconformities.
- checked that equipment has been properly tested and calibrated.
- undertaken to carry out the above measures on a regular basis through a surveillance process, to verify that the specifications and quality control being operated by the manufacturer are being maintained.

2.3 The management system of the Certificate holder has been assessed and registered as meeting the requirements of BS EN ISO 9001 : 2015 by AB Certification (Certificate A2980).

3 Delivery and site handling

3.1 GeoStrap and HA GeoStrap Reinforcement for reinforced soil retaining walls and bridge abutments are delivered to site in 100 m coils, wrapped in transparent polythene film.

3.2 Each coil of GeoStrap and HA GeoStrap Reinforcement includes a label bearing the product name, product type, characteristic strength, coil length and weight, product width and constituent materials (see Figure 8).

Figure 8 Label

GEOSTRIP	
TYPE	GEOSTRAP 5
CHARACTERISTIC STRENGTH	50 KN
LENGTH / WEIGHT	100 M / 14 ± 1 KG
WIDTH	50 MM
RUN No	
SHEATH	POLYETHYLENE
YARN	HIGH-TENACITY POLYESTER
TERRE ARMEE	



3.3 Care should be taken to prevent damage to the products during transit and handling, and whilst in storage.

3.4 The products should be stored under cover, in clean, dry conditions and should be protected from exposure to UV light and extreme temperatures (see also section 8.1).

3.5 Precast concrete facing units and other components should be handled and stored in accordance with the manufacturers’ instructions, the requirements of BS 8006-1 : 2010, BS EN 14475 : 2006 and the MCHW, Volume 1.

Assessment and Technical Investigations

The following is a summary of the assessment and technical investigations carried out on GeoStrap and HA GeoStrap Reinforcement for reinforced soil retaining walls and bridge abutments.

Design Considerations

4 General

4.1 When designed and installed in accordance with this Certificate, the products are satisfactory for use in the construction of reinforced soil retaining walls and bridge abutments.

4.2 Structural stability is achieved by the connection strength between GeoStrap and precast concrete facing units, and by the frictional interaction between the soil particles and GeoStrap and HA GeoStrap Reinforcement.

4.3 The fill specification and method of placement, compaction and design strength of GeoStrap and HA GeoStrap Reinforcement, and length of embedment within the compacted fill material are key design factors.

4.4 Prior to the commencement of work, the designer must satisfy the design approval and certification procedures of the relevant Highway Authority.

4.5 The BBA has not assessed the structures for supporting parapet loading caused by vehicle collision at the top of the precast concrete facing units.

4.6 Particular attention should be paid in design to:

- site preparation
- fill material properties
- specification for placing and compaction of the fill material
- drainage
- protection of GeoStrap and HA GeoStrap Reinforcement against damage during installation
- design of the precast concrete facing units and means of attachment of GeoStrap and HA GeoStrap Reinforcement
- the required construction tolerances for the completed structure.

4.7 Typical sectional and plan views of reinforced soil structures constructed using GeoStrap and HA GeoStrap Reinforcement are shown in Figures 9 and 10.

Figure 9 Typical reinforced soil structure — diagrammatic sectional view

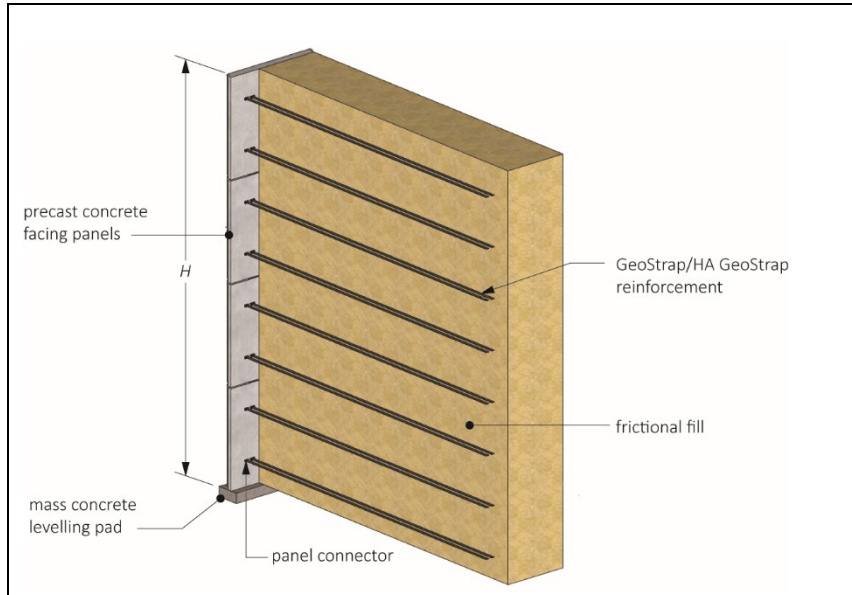
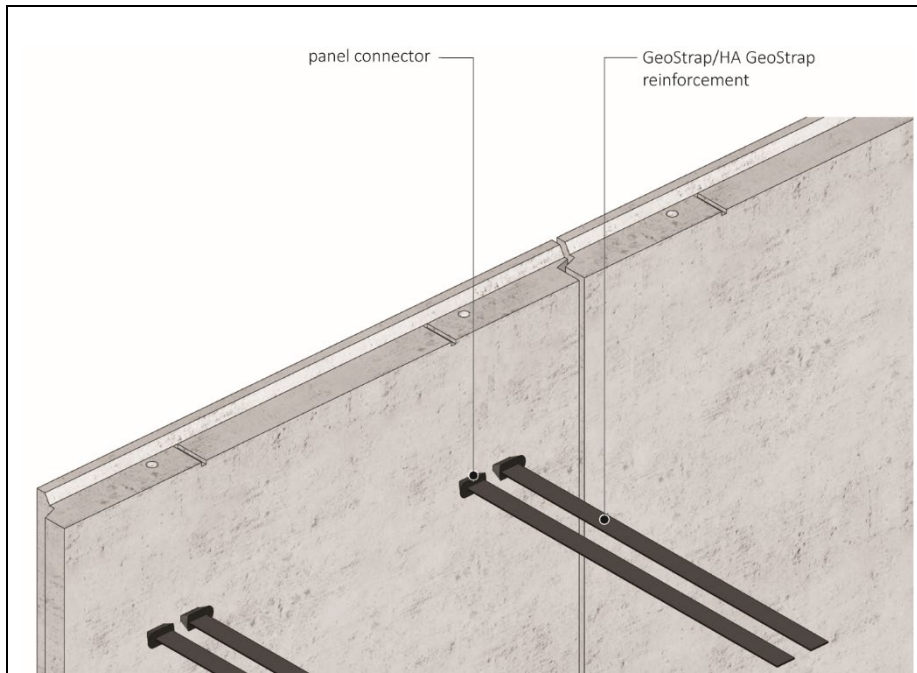

Figure 10 Typical reinforced soil structure — diagrammatic plan view



Note: Figures 9 and 10 show the GeoMega connector but can be replaced for any connections included in this certificate.

5 Practicability of installation

GeoStrap and HA Geostrap Reinforcement for reinforced soil retaining walls and bridge abutments are installed in accordance with the specifications and construction drawings by trained contractors.

6 Design

Design methodology

6.1 Reinforced soil retaining walls and bridge abutments constructed using the products should be designed in accordance with BS 8006-1 : 2010 and the MCHW, Volume 1.

6.2 In accordance with BS 8006-1 : 2010, Table 7, the required design life for permanent walls and bridge abutments is 120 years.

GeoStrap and HA GeoStrap Reinforcement

6.3 The design strength of GeoStrap and HA Geostrap Reinforcement (T_D) is calculated as:

- for ultimate limit state (ULS): $T_D = T_{CR}/f_m$
- for serviceability limit state (SLS): $T_D = T_{CS}/f_m$

where:

T_{CR} is the long-term tensile creep rupture strength of the reinforcement at the specified design life and design temperature

T_{CS} is the maximum allowable tensile load to ensure that the prescribed post-construction, limiting strain specified for the SLS is not exceeded

f_m is the material safety factor to allow for the strength reducing effects of installation damage, weathering (including exposure to sunlight), chemical and other environmental effects and to allow for the extrapolation of data required to establish the above reduction factors.

6.4 The long-term tensile creep rupture strength (T_{CR}) for each grade of GeoStrap and HA GeoStrap Reinforcement is calculated using the formula:

$$T_{CR} = T_{char}/RF_{CR}$$

where:

T_{char} is the characteristic short-term strength taken from Table 1

RF_{CR} is the reduction factor for creep (see section 7).

6.5 The material safety factor f_m used in determining T_D is calculated as:

$$f_m = RF_{ID} \times RF_W \times RF_{CH} \times f_s$$

where:

RF_{ID} is the reduction factor for installation damage

RF_W is the reduction factor for weathering, including exposure to UV light

RF_{CH} is the reduction factor for chemical/environmental effects

f_s is the factor of safety for the extrapolation of data.

6.6 Recommended values for RF_{CR} , RF_{ID} , RF_W , RF_{CH} and f_s are given in sections 7 to 9. Conditions of use outside the scope for which the reduction factors are defined are not covered by this Certificate and advice should be sought from the Certificate holder.

6.7 Tests have shown that the design strength of GeoStrap and HA GeoStrap Reinforcement is reduced locally at the point that it is bent to a tight radius around the connection toggle or GeoMega connector. Reduction factors for use in design are given in section 7.

Soil/GeoStrap and HA GeoStrap Reinforcement interaction

6.8 For the purpose of checking direct sliding and pull-out resistance, the friction coefficient (a') relating soil friction angle to the soil/GeoStrap and HA Geostrap Reinforcement bond can be taken conservatively as 0.6. Enhanced values of a' can be justified in design, by carrying out soil and site-specific pull-out tests in accordance with BS EN 13738 : 2004.

Concrete facing units

6.9 The precast concrete facing units must be designed in accordance with the relevant provisions of BS 8006-1 : 2010, BS EN 14475 : 2006, BS EN 1990 : 2002 and its UK National Annex, and BS EN 1992-2 : 2005 and its UK National Annex.

6.10 The appropriate combination of concrete exposure classes should be selected from BS 8500-1 : 2015, Table A.1, and BS EN 206 : 2013, Table 1, to suit the proposed location and level of exposure of the proposed structure. Design

and detailing of the precast concrete facing units should provide adequate durability for an intended design life of at least 100 years.

6.11 Where precast concrete facing units are to be embedded in soils which could be potentially aggressive, the guidance in BRE Special Digest 1 : 2005 should be followed.

6.12 Where connection loops and toggles are used for connection of GeoStrap and HA GeoStrap Reinforcement, these should be designed in accordance with the requirements of BS 8006-1 : 2010 and with adequate anchorage strength.

6.13 The Certificate holder's advice should be sought where it is proposed to use GeoMega, GeoCore or FelxiCore connectors to form the connection.

Fill materials

6.14 Fill materials should satisfy the requirements of BS 8006-1 : 2010 and the MCHW, Volume 1 .

7 Mechanical properties

Short-term tensile strength

7.1 The characteristic short-term tensile strength of each grade of GeoStrap and HA GeoStrap Reinforcement is given in Tables 1 and 2 respectively.

7.2 A typical short-term stress/strain curve is shown in Figure 11. The average strain at breaking load is $12\% \pm 4\%$.

Figure 11 Typical short-term stress/strain curve

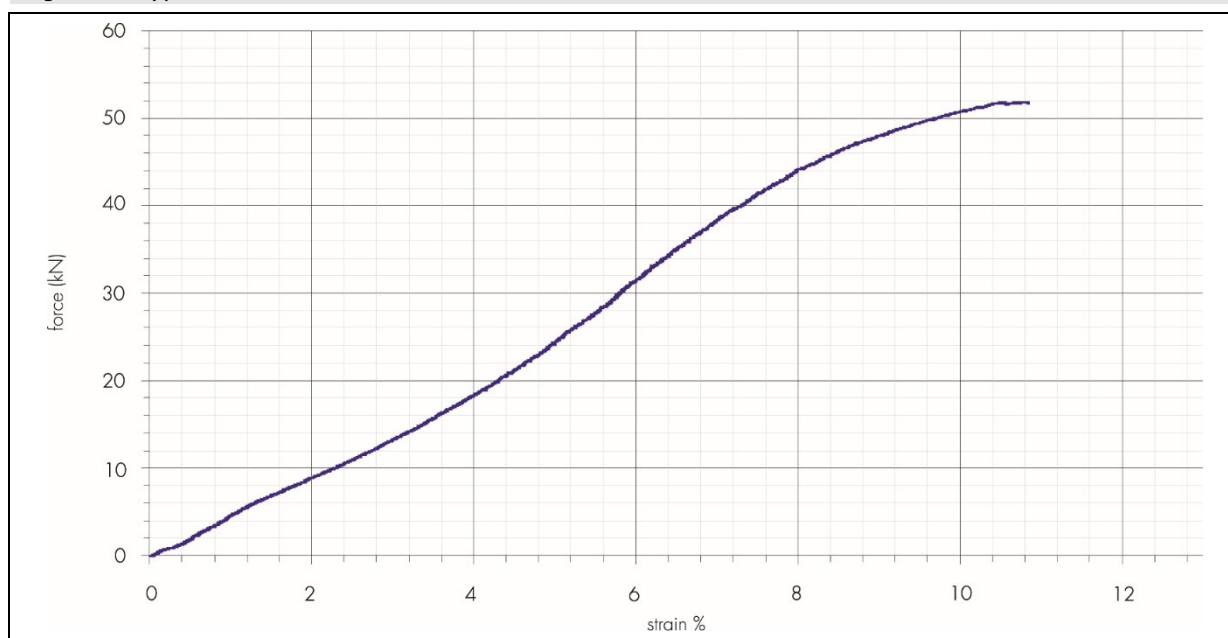

Long-term tensile creep rupture strength

7.3 The long-term creep rupture performance of the products has been determined in accordance with the principles of PD ISO/TR 20432 : 2007. A stress rupture line (see Figure 12) has been determined using conventional long-term creep rupture test data (up to 2,000 hours) and time-shifted stepped isothermal method (SIM) test data (up to 58,500 hours) for the load carrying polyester yarn used for manufacture of the products. As the amount of available conventional test data was limited to 2,000 hours, the long-term creep performance of the load-carrying polyester has also been compared with that of other similar products, for which data is available in the public domain. The factor of safety for the extrapolation of data (f_s) presented in section 8 takes into account of the extent of available data.

Figure 12 Regression line for life expectancy at constant stress defined by percentage of characteristic short-term tensile strength

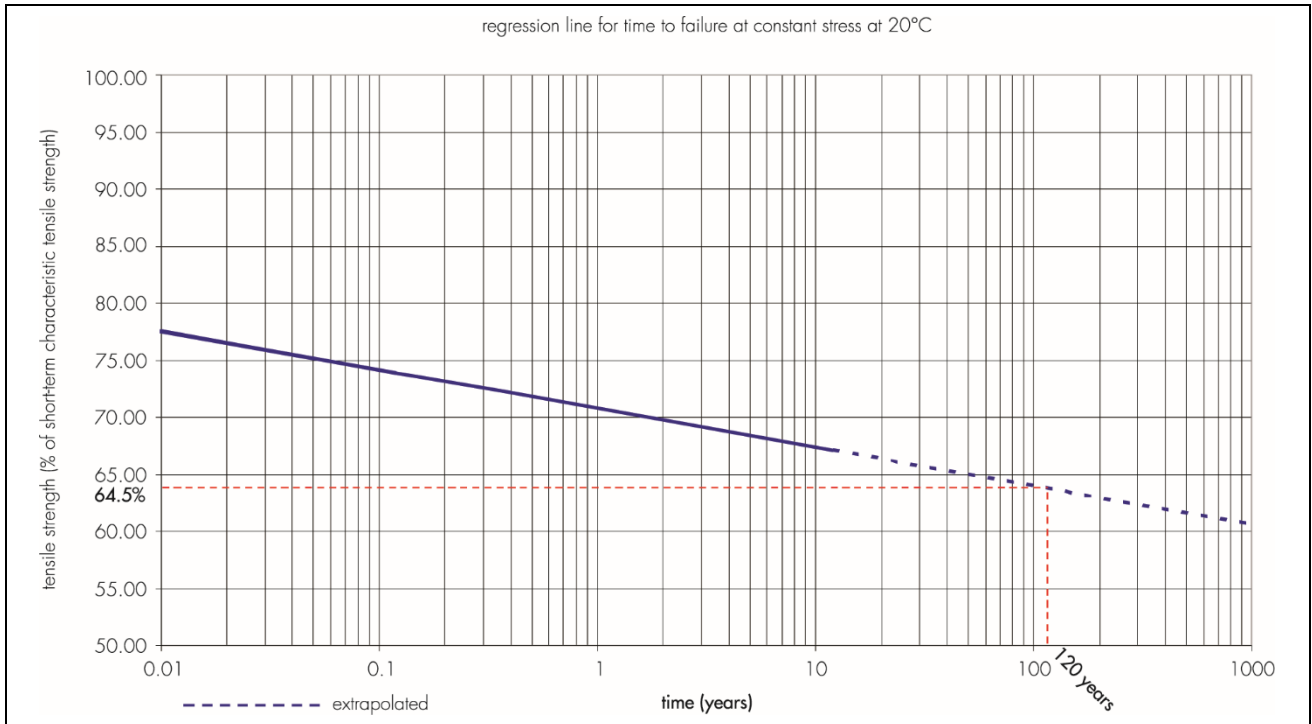

7.4 For a 120-year design life and design temperature of 20°C, the long-term tensile strength (T_{CR}) for the products can be taken as 64.5% of characteristic short-term tensile strength (T_{char}), giving a long-term creep reduction factor (RF_{CR}) of 1.55.

Post construction strain

7.5 The prescribed maximum allowable post-construction creep strains allowed by BS 8006-1 : 2010 for the SLS of reinforced soil retaining walls and bridge abutments are shown in Table 3 of this Certificate.

Table 3 Serviceability limits on post-construction internal strains for bridge abutments and retaining walls

Structure	Strain (%)	Design period for the purposes of determining limiting strain
Bridge abutments and retaining walls with permanent structural loading	0.5	2 months – 120 years
Retaining walls, with no applied structural loading i.e. transient live loadings only	1.0	1 month – 120 years

7.6 The relationship between the prescribed post-construction strain limit and the tensile load (T_{CS}), causing that post-construction strain is illustrated in Figure 13

Figure 13 Definition of T_{CS}

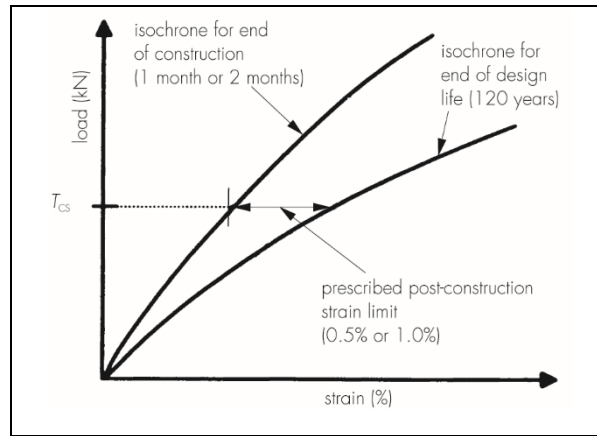

7.7 Reduction factors $RF_{CR(SLS)}$ for determining T_{CS} from the characteristic short-term tensile load (T_{Char}) for each grade of GeoStrap Reinforcement are given in Table 4. The following formula is used to calculate T_{CS} :

$$T_{CS} = T_{Char} / RF_{CR(SLS)}$$

Table 4 Long-term creep reduction factors for serviceability limit state for a 120-year design life and design temperature of 20°C

Prescribed allowable post-construction strain (%)	$RF_{CR(SLS)}$
0.5	2.00
1.0	1.54

Reduction factor for installation damage (RF_{ID})

7.8 To allow for loss of strength due to mechanical damage sustained during installation, the appropriate reduction factor (RF_{ID}) should be selected from Table 5. These reduction factors have been established from full-scale installation damage tests using a range of materials. For soils not covered by Table 5, appropriate values of RF_{ID} may be determined from site-specific trials or the engineer responsible for design of the project may exercise engineering judgment to interpolate between the values given. The reduction factors shown assume that well-graded material is used with a minimum compacted depth of 150 mm.

Table 5 Reduction factors for installation damage (RF_{ID})

GeoStrap Reinforcement type/grade (kN)	RF_{ID}		
	Particle size d_{100}/d_{50} (mm)		
	5/1.5	32/8	125/26
5/37.5	1	1.02	1.09
5/50	1	1	1.01
5/65	1	1.01	1.03
9/30	1	1.07	1.21
9/50	1	1.03	1.15
9/75	1	1.03	1.15
9/100	1	1.02	1.11

Connection strength

7.9 The connections must be designed by the certificate holder based on their strength and properties.

8 Effects of environmental conditions

Weathering (including exposure to UV light)

8.1 Evidence from tests in accordance with BS EN 12224 : 2000 shows that the products have adequate resistance to weathering and exposure to UV light, when protected in accordance with the recommendations of this Certificate and provided they are covered within one month of installation. Subject to compliance with this exposure time limit, a reduction factor (RF_w) of 1.0 may be used for design purposes. Exposure periods of up to four months may be acceptable depending upon the season and location, but are outside of the scope of this Certificate. Further guidance is given in PD ISO/TR 20432 : 2007.

Chemical and biological degradation

8.2 Evidence from tests in accordance with BS EN 12447 : 2001 shows that the products have adequate resistance to hydrolysis for soil environments typically encountered in the UK.

8.3 Evidence from tests in accordance with BS EN 12225 : 2000 shows that the products are highly resistant to microbiological attack.

8.4 For a design life of 120 years, a design temperature of 20°C and soil environments with pH values between 4.0 and 9.0, the reduction factor for chemical/environmental effects (RF_{CH}) for the products should be taken as 1.10.

9 Factor of safety for the extrapolation of data (f_s)

For GeoStrap and HA GeoStrap Reinforcement, the factor of safety for the extrapolation of data (f_s) should be taken as 1.15 for a 120-year design life and design temperature of 20°C.

10 Maintenance

As the products are confined within the soil and have suitable durability, maintenance is not required.

11 Durability

11.1 GeoStrap and HA GeoStrap Reinforcement for reinforced soil retaining walls and bridge abutments will have adequate durability for a design life of 120 years when used and installed in accordance with the provisions of this Certificate.

11.2 The precast concrete facing units will have adequate durability for the proposed life of the structure under exposure conditions normally encountered in reinforced earth retaining walls and bridge abutments in the UK when designed and installed in accordance with the provisions of BS 8006-1 : 2010, BS EN 14475 : 2006 and the requirements of this Certificate (see sections 6.8 to 6.12).

12 Re-use and recyclability

12.1 The precast concrete facing units can be crushed and re-used as aggregate. The fill material can be re-used.

12.2 The steel loops and toggles can be readily recycled.

Installation

13 General

13.1 Installation should be carried out in accordance with the Certificate holder's installation instructions, the requirements of BS EN 14475 : 2006 and the MCHW, Volume 1.

13.2 The site is prepared, including excavation and installation of drainage systems and a concrete levelling pad.

13.3 The initial course of precast concrete facing units is set and braced using wedges and clamps to hold the units in position (see Figure 14). The units are given a slight batter towards the backfill to accommodate the outward movement that will occur as the fill material is placed and compacted.

Figure 14 Temporary anchorage of concrete facing panels

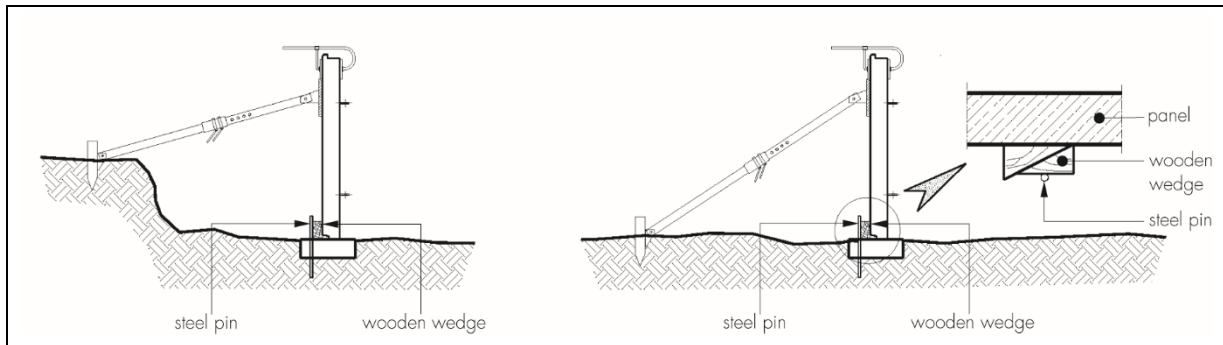

13.4 Lengths of the products are cut to the required dimensions and threaded around the facing unit attachment toggles, or pulled through GeoMega, GeoCore or FlexiCore connectors as appropriate (see Figures 2 and 3). Where GeoMega, GeoCore or FlexiCore connectors are selected as the means of connection of the products to the facing units, a draw chord may be required to pull the strip through the connector.

13.5 The strips are laid flat across the fill, parallel to each other and perpendicular to the facing panels. They are then pulled taut and fixed in position using timber pegs or steel pins. Care should be taken to ensure that products are not twisted.

13.6 To assist in tightening the products before the next layer of soil is placed, a 150 mm deep step, or a 100 mm deep by 500 mm wide trench is excavated at a point 500 mm from the end of the reinforcement.

13.7 Placing of fill material is started at the free ends of GeoStrap and HA GeoStrap Reinforcement, furthest from the facing panels and over the step/trench excavated to assist in tightening the reinforcement. Filling continues progressively outwards to within 2 m of the back face of the facing units. The remaining 2 m of fill material should be placed and compacted using lighter compaction plant in accordance with the unit manufacturer's recommendations. Backfill is placed and compacted in layers as specified by the designer until the next course of reinforcement is reached, or to within 75 to 150 mm of the top edge of the precast concrete facing units.

13.8 The construction sequence is repeated, with further courses of precast concrete facing units, GeoStrap and HA GeoStrap Reinforcement, and fill material added, until the formation level for the parapet base or finished level of the structure is reached.

13.9 Vehicles and other construction plant should not be allowed to run directly on GeoStrap and HA GeoStrap Reinforcement until it has been adequately covered with fill material.

Technical Investigations

14 Tests

Dimensional checks have been carried out on each grade of GeoStrap and HA GeoStrap Reinforcement for reinforced soil retaining walls and bridge abutments.

15 Investigations

15.1 The manufacturing process was evaluated, including the methods adopted for quality control, and details were obtained of the quality and composition of the materials used.

15.2 An examination was made of test data relating to:

- long- and short-term tensile properties
- resistance to damage caused during installation
- long- and short-term load/strain characteristics

- connection strength
- resistance to weathering including exposure to ultra-violet light
- resistance to hydrolysis
- resistance to biological degradation.

Bibliography

BRE Special Digest 1 : 2005 *Concrete in aggressive ground : Part C Assessing the aggressive chemical environment*

BS 8006-1 : 2010 + A1 : 2016 *Code of practice for strengthened/reinforced soils and other fills*

BS 8500-1 : 2015 + A2 : 2019 *Concrete — Complementary British Standard to BS EN 206— Method of specifying and guidance for the specifier*

BS EN 206 : 2013 + A2 : 2021 *Concrete – Specification, performance, production and conformity*

BS EN 1990 : 2002 + A1 : 2005 *Eurocode — Basis of structural design*

NA to BS EN 1990 : 2002 + A1 : 2005 *UK National Annex to Eurocode — Basis of structural design*

BS EN 1992-2 : 2005 *Eurocode 2 — Design of concrete structures — Concrete bridges — Design and detailing rules*

NA to BS EN 1992-2 : 2005 *UK National Annex to Eurocode 2 — Design of concrete structures — Concrete bridges — Design and detailing rules*

BS EN 12224 : 2000 *Geotextile and geotextile-related products — Determination of the resistance to weathering*

BS EN 12225 : 2000 *Geotextile and geotextile-related products — Method for determining the microbiological resistance by a soil burial test*

BS EN 12447 : 2001 *Geotextiles and geotextile-related products — Screening test method for determining the resistance to hydrolysis in water*

BS EN 13251 : 2016 *Geotextiles and geotextile-related products — Characteristics required for use in earthworks, foundations and retaining structures*

BS EN 13738 : 2004 *Geotextiles and geotextile-related products — Determination of pullout resistance in soil*

BS EN 14475 : 2006 *Execution of special geotechnical works — Reinforced fill*

BS EN ISO 9001 : 2015 *Quality management systems — Requirements*

BS EN ISO 10319 : 2015 *Geotextiles — Wide-width tensile test*

Manual of Contract Document for Highway Works, Volume 1 *Specification for Highway Works Amendment November 2021*

PD ISO/TR 20432 : 2007 *Guidelines for the determination of the long-term strength of geosynthetics for soil reinforcement*

16 Conditions

16.1 This Certificate:

- relates only to the product/system that is named and described on the front page
- is issued only to the company, firm, organisation or person named on the front page – no other company, firm, organisation or person may hold or claim that this Certificate has been issued to them
- is valid only within the UK
- has to be read, considered and used as a whole document – it may be misleading and will be incomplete to be selective
- is copyright of the BBA
- is subject to English Law.

16.2 Publications, documents, specifications, legislation, regulations, standards and the like referenced in this Certificate are those that were current and/or deemed relevant by the BBA at the date of issue or reissue of this Certificate.

16.3 This Certificate will remain valid for an unlimited period provided that the product/system and its manufacture and/or fabrication, including all related and relevant parts and processes thereof:

- are maintained at or above the levels which have been assessed and found to be satisfactory by the BBA
- continue to be checked as and when deemed appropriate by the BBA under arrangements that it will determine
- are reviewed by the BBA as and when it considers appropriate.

16.4 The BBA has used due skill, care and diligence in preparing this Certificate, but no warranty is provided.

16.5 In issuing this Certificate the BBA is not responsible and is excluded from any liability to any company, firm, organisation or person, for any matters arising directly or indirectly from:

- the presence or absence of any patent, intellectual property or similar rights subsisting in the product/system or any other product/system
- the right of the Certificate holder to manufacture, supply, install, maintain or market the product/system
- actual installations of the product/system, including their nature, design, methods, performance, workmanship and maintenance
- any works and constructions in which the product/system is installed, including their nature, design, methods, performance, workmanship and maintenance
- any loss or damage, including personal injury, howsoever caused by the product/system, including its manufacture, supply, installation, use, maintenance and removal
- any claims by the manufacturer relating to CE marking.

16.6 Any information relating to the manufacture, supply, installation, use, maintenance and removal of this product/system which is contained or referred to in this Certificate is the minimum required to be met when the product/system is manufactured, supplied, installed, used, maintained and removed. It does not purport in any way to restate the requirements of the Health and Safety at Work etc. Act 1974, or of any other statutory, common law or other duty which may exist at the date of issue or reissue of this Certificate; nor is conformity with such information to be taken as satisfying the requirements of the 1974 Act or of any statutory, common law or other duty of care.